



EXPLORE THE CLIMATE

## USER MANUAL

### CE376 EYE-SAFE LIDAR

Models: I376-KIT-LGPN/LGP/LGN/LG/LN D



Questions or Concerns?

[support@cinel.fr](mailto:support@cinel.fr)

EN

## EN – ENGLISH

### TABLE OF CONTENTS

Package Contents	2
Specifications	3
Safety Information	4
Getting to Know Your CE376 LiDAR	5
Getting Started	6
Options	8
Care & Maintenance	9
Troubleshooting	10
Warranty Information	11
Customer Support	11

### PACKAGE CONTENTS

- 1 x CE376 LiDAR
- 1 x Flight-case
- 1 x Power supply cable (5 m)
- 1 x Ethernet Communication cable (20 m)
- 1 x Ethernet-USB converter
- 1 x USB-B to USB-A cable
- 1 x User Manual
- 1 x USB key with software and calibration files

## SPECIFICATIONS

<b>Power Supply</b>	100 -250 VAC 50/60Hz Hz
<b>Fuse Characteristics</b>	slow blow T6.3A
<b>Typical Power Consumption</b>	40 W
<b>Maximum Power Consumption</b>	200 W
<b>Operating Conditions</b>	<u>Temperature:</u> +18°C – +28°C / 65°F – 82°F  <u>Humidity:</u> 5% to 75%
<b>Dimensions</b>	713 x 463 x 691 mm / 28 x 18.2 x 26.8 in
<b>Weight</b>	35 kg / 77 lb
<b>Computer interface</b>	USB 2.0
<b>Acquisition Mode</b>	Photon counting
<b>Acquisition time</b>	1 s to 1200 s
<b>Maximum range measurement</b>	30720 m
<b>Minimum range measurement</b>	50 m
<b>Range resolution</b>	15 m

### NIR CHANNELS

<b>Available in CE376 models</b>	GPN, GN, N
<b>Wavelength</b>	808 nm
<b>EYE-SAFE</b>	IEC 60825-1 compliant
<b>Depolarization Channel</b>	NO
<b>Laser Divergence</b>	460 µrad
<b>FOV Reception</b>	520 µrad

### GREEN CHANNELS

<b>Available in CE376 models</b>	GPN, GP	GN, G
<b>Wavelength</b>	532 nm	
<b>EYE-SAFE</b>	IEC 60825-1 compliant	
<b>Depolarization Channel</b>	YES	NO
<b>Laser Divergence</b>	<50 µrad	
<b>FOV Reception</b>	230 µrad	

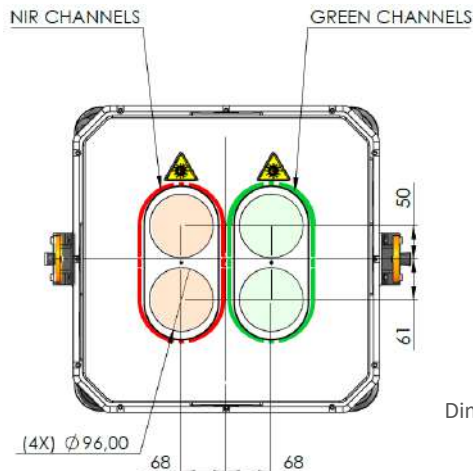

Dimensions are in mm.

# READ AND SAVE THESE INSTRUCTIONS

## SAFETY INFORMATION

To reduce the risk of electric shock, eye-damage or other injury, please follow all instructions and safety guidelines.

### GENERAL SAFETY

- Only use your CE376 LiDAR as described in this manual.
- Do not use your CE376 LiDAR outdoors. It is not waterproof.
- Do not use in excessively humid area.
- Do not use your CE376 in a closed room without a roof window or a hatch above it.
- It requires at least 2 persons to lift a CE376 LiDAR. Take care to use your leg muscles instead of your back. Keep the CE376 LiDAR steady when moving.
- Do not drop, hit, flip or lay your CE376 LiDAR on its sides. Any of these actions might demand the technical intervention of a CIMEL qualified operator.
- Do not remove the cover of your CE376 LiDAR.
- Do not cover the vents.
- Do not place any heavy objects on the CE376 LiDAR.
- Do not try to put any object or hands inside your CE376 LiDAR through vents or traps.
- Do not use your CE376 LiDAR if it is damaged or not working correctly, or if the power supply cable or plug is damaged. Do not try to repair or re-align it yourself. Contact Customer Support (see p.11).

### LASER SAFETY



- Do not stare inside your CE376 LiDAR through the windows when it is switched ON. The laser beam is considered safe with blink reflex (0.25 s) but can damage retina for longer exposure.
- Do not look inside your CE376 LiDAR through a magnifying glass or any optical instruments when it is switched ON.
- Do not try to open your CE376 LiDAR, or make it work without its cover. CIMEL cannot be held responsible for any injury occurring when the cover is removed.

## GETTING TO KNOW YOUR CE376 LIDAR

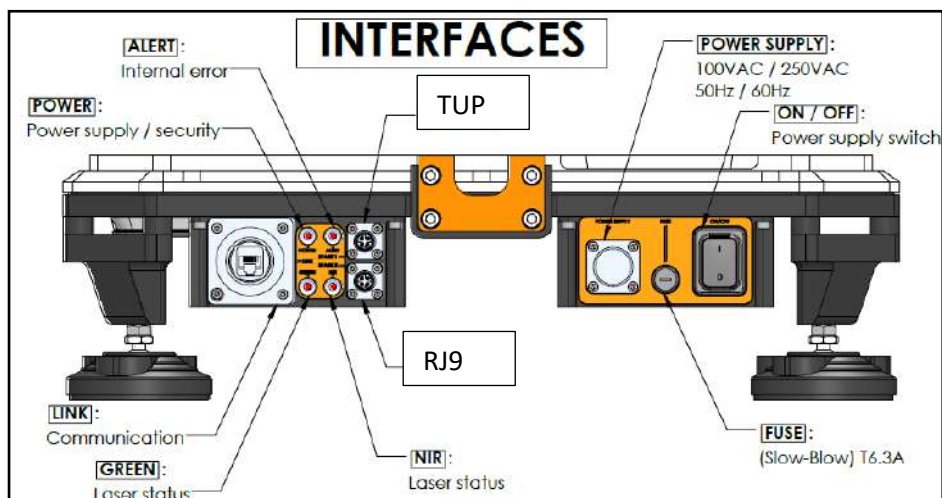

## GETTING STARTED

1. In order to use your CE376 LiDAR you need either a thermal enclosure I376-ENC-X or a **regulated and temperate environment** with a **non-tempered glass** window on the roof or a hatch (to be used only in non-raining conditions).
2. Place your CE376 LiDAR in as follows:
  - It is preferable to place the CE376 LiDAR in a **shady place**.
  - If the site is close to **Equator**, protect the LiDAR from direct sunlight at midday.
  - If the site is in the **North** Hemisphere: place your CE376 LiDAR with its lower side pointing **North**.
  - If the site is in the **South** Hemisphere: place your CE376 LiDAR with its lower side pointing **South**.

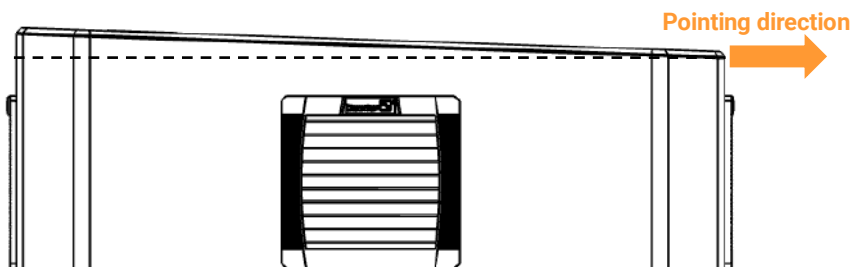

3. Remove the blue plastic tape from all glasses or windows.
4. Remove the covers over LINK connector and POWER SUPPLY connector and connect the communication cable and the power supply cable, respectively.

→ All CE376 LiDAR connectors have a key-connection.

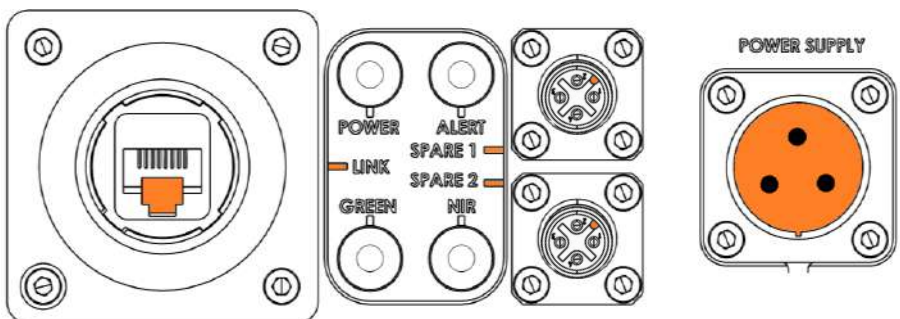

5. Connect the other side of the communication cable to the Link port of the Ethernet-USB converter box, and the USB cable connector USB B to the other port.



6. Install the software Lidar2.exe and drivers on your computer following the Software Manual instructions (provided on the USB key).
7. Connect the USB cable to your computer and Power ON your CE376 LiDAR.
8. **On the Interface** of your CE376 LiDAR all external LEDs should blink green for 1.8s then go OFF except for the POWER LED that should stay green [A].
9. After clicking on the POWER ON button from the Lidar2.exe software, both the

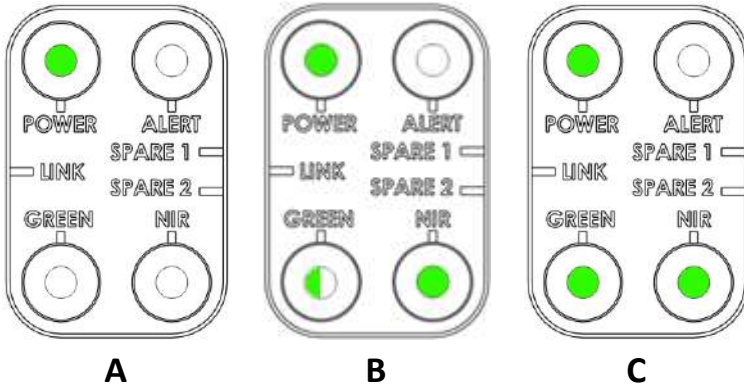

GREEN and NIR LEDs should turn green to indicate that both lasers are switched ON. If any of the laser LEDs is blinking green, this means the laser source needs time to reach nominal temperature (few seconds to 3 minutes) before firing [B].

10. After a few seconds, the POWER, GREEN and NIR LEDs should all be green. All lasers are ON [C].

→ Note that if the model of your CE376 LiDAR doesn't include one specific wavelength (GP, G or N), the corresponding laser source LED will be disabled.

## OPTIONS

### THERMAL ENCLOSURE

Model	I376-ENC-1	I376-ENC-2
<b>Power Supply</b>	115 VAC (50Hz/60Hz)	
<b>Typical Power Consumption</b>	1300 W	
<b>Cooling Capacity</b>	3940/4104 BTU/Hr.	5585/6180 BTU/Hr.
<b>Operating Conditions</b>	Temperature: -30°C – +55°C / -22°F – 130°F Humidity: 0% – 100% An additional internal dehumidifier is needed if temperature and humidity are high (Dew point temperature > 19°C)	
<b>Dimensions</b>	90 x 95 x 130 cm / 35.4 x 37.4 x 51.2 in	
<b>Weight</b>	93 kg / 205 lb	

Model	I376-ENC-3	I376-ENC-4
<b>Power Supply</b>	230 VAC (50Hz/60Hz)	
<b>Typical Power Consumption</b>	1300 W	
<b>Cooling Capacity</b>	4269/4703 BTU/Hr.	5469/5965 BTU/Hr.
<b>Operating Conditions</b>	Temperature: -30°C – +55°C / -22°F – 130°F Humidity: 0% – 100% An additional internal dehumidifier is needed if temperature and humidity are high (Dew point temperature > 19°C)	
<b>Dimensions</b>	90 x 95 x 130 cm / 35.4 x 37.4 x 51.2 in	
<b>Weight</b>	93 kg / 205 lb	

With this option, connect your CE376 LiDAR to the cables inside the Thermal Enclosure and connect externally the Power Supply cable and the communication Cable delivered with your CE376 LiDAR to the Thermal Enclosure on the outside.



## CARE AND MAINTENANCE

### CLEANING WINDOW

Depending on the weather conditions, it is recommended to clean the window through which is placed your CE376 LiDAR at least once a week.

If your CE376 LiDAR is in a Thermal Enclosure, clean the window of the Thermal Enclosure with water and a smooth cloth.

### TEMPERATURE INSIDE YOUR CE376 LiDAR

In Lidar2.exe software, check in monitoring data the temperature inside your CE376 LiDAR. If any anomaly occurs, check that the thermal enclosure is working properly.

### AFTER-PULSE CALIBRATION

It is recommended to perform an After-Pulse calibration every month. Put a dark cloth over the outside window of your CE376 LiDAR in order to block laser light completely and perform an After-Pulse Calibration with the software Lidar2.exe for 600 s.

### POLARIZATION CALIBRATION

It is recommended to perform a polarization calibration twice a year on your CE376 LiDAR. Contact Support for further details (may necessitate an intervention on the acquisition PC).

### ROUTINE MAINTENANCE

It is recommended to do a check-up maintenance of your CE376 LiDAR every year after its installation by a CIMEL qualified operator. Maintenance is not included in the warranty of the product.

### MOVING YOUR CE376 LiDAR

If you plan to use your CE376 LiDAR on a field campaign or on another site, the intervention of a CIMEL qualified operator could be necessary. Contact Support for further details.

## TROUBLESHOOTING

Problem	Possible Solution
GREEN LED blinks green	The laser is reaching its nominal temperature. Wait a few moments until it turns green.
GREEN LED blinks red	Green laser issue. Power OFF your CE376 LiDAR in the Lidar2.exe software and Power ON again. If the problem persists, Power OFF your CE376 LiDAR with the main switch, wait a few seconds and switch Power ON.
NIR LED blinks green	The laser is reaching its nominal temperature. Wait a few moments until it turns green.
NIR LED blinks red	NIR laser issue. Power OFF your CE376 LiDAR with the main switch and disconnect from the power outlet. Wait a few seconds before plugging it back and Power ON.
ALERT LED blinks red	Internal issue, please contact Support.
All LED green but no laser beam visible	The NIR laser source is invisible to the eye. By day the green laser beam can be difficult to see. To check if the green the laser is on, put a white paper sheet above the lidar to see the laser beam.
The CE376 LiDAR doesn't power ON	Verify that the Instrument is plugged into an electrical outlet.  If there is no issue with the electrical outlet, check the condition of the fuse. In case the fuse is damaged, replace it by a new one with the same characteristics (slow blow T6.3A).  If the CE376 LiDAR is used with the optional CIMEL Thermal Enclosure, check if the circuit breaker inside is properly operating.
Droplets or dew on the Thermal Enclosure window	This may happen in the morning and/or after rain. Remove the water from the glass manually, or let it evaporate by itself after a few hours.
Condensation in the Thermal Enclosure window	Use a dehumidifier.

If any of these issues persist, please contact Support.

## WARRANTY INFORMATION

### TERMS & POLICY

CIMEL warrants all its products to be of the highest quality in materials, workmanship and service for one year from the date of delivery, covering the instrument as a whole and its components.

The condition of this guarantee is the correct use of the instrument. In fact, CIMEL reserves the right, after diagnosis at the CIMEL factory, not to apply the warranty if the conditions are not met.

To extend the warranty period, please contact our sales team to request a quote.

## CUSTOMER SUPPORT

### CIMEL

172 Rue de Charonne  
75011 PARIS  
FRANCE

**Email:** [support@cimel.fr](mailto:support@cimel.fr)

\*Please have the Model and Serial Number of your CE376 LiDAR ready before contacting Customer Support.

